



LOCTITE® **EQUIPMENT**

OPERATION MANUAL

Hysol® 175-AIR

P/N 98036

Hysol® 175-AIR-HT

P/N 98040



LOCTITE

Loctite Americas
1001 Trout Brook Crossing
Rocky Hill, CT 06067-3910

Loctite Brazil
Av. Prof. Vernon Kriebel, 91
06690-11-Itapevi
São Paulo-Brazil

Loctite Canada Inc.
2225 Meadowpine Boulevard
Mississauga, Ontario L5N 7P2

Loctite Company de México, S.A. de C.V.
Calzada de la Viga s/n, Fracc. Los Laureles
Loc. Tulpetlac, C.P. 55090
Ecatepec de Morelos, Edo. de México,
México

www.loctite.com

A  Company

Loctite is a trademark of Loctite Corporation, U.S.A.
© Copyright 2001. Loctite Corporation. All rights reserved.

Data in the manual is subject to change without notice.
985067 06/01

Contents

1.	Please Observe the Following	2
1.1.	Safety	2
1.2.	Items supplied.....	2
2.	Description	2
3.	Technical Data	3
4.	Installation	3
5.	Operation	4
5.1.	Adhesive Flow Rate Adjustment	4
6.	Application Hints	5
7.	Troubleshooting	5
8.	Care and Maintenance	6
9.	Accessories and Spare Parts	6
10.	Warranty	8
11.	Appendix	9
12.	Exploded View	10
13.	Parts List	11

1. Please Observe the Following

1.1. Safety



Do not touch the nozzle or molten adhesive with bare skin as they are hot - the operating temperature of the Loctite® Hysol® 175-AIR and 175-AIR-HT applicators is approximately 400°F (200°C). Protective gloves should always be worn. Careless handling can cause skin burns. If molten adhesive comes into contact with the skin immerse the affected area immediately in plenty of cold water. Seek medical advice if necessary.

In addition to the safety instructions herein, any statutory regulations, local fire insurance regulations, or other generally valid “regulations for accident prevention” must be complied with when using this tool.

- Never use the tool if it is damaged in any way.
- Do not use this tool in damp rooms, outdoors while it is raining, or where there is high humidity.
- Do not use this tool in the vicinity of any heat-sensitive materials, or any flammable materials, liquids, or gases.
- Only use extension cables that meet the specification shown in “Technical data”.
- Never pull on the tool’s connecting cable.

1.2. Items supplied

Loctite® Hysol® 175-AIR

Pneumatically-driven Hot Melt Cartridge Dispenser, fitted with 383°F (195°C) thermostat (suitable for standard EVA-based hotmelt adhesives)

Valve body air line adaptor

Plastic Stand

Manual

Loctite® Hysol® 175-AIR-HT

Pneumatically-driven Hot Melt Cartridge Dispenser, fitted with 400°F (204°C) thermostat (suitable for polyamide hotmelt adhesives)

Valve body air line adaptor

Plastic Stand

Manual

2. Description

The Loctite® Hysol® 175-AIR and 175-AIR-HT are the highest output, hand-held industrial hotmelt applicators available. With its two powerful 250W stainless steel cartridge heaters, they are capable of dispensing up to 9 lbs. of molten hotmelt per hour; yet only take 10 minutes to warm up from cold.

Supported by a range of adhesive formulations, the Loctite® Hysol® 175-AIR and 175-AIR-HT are suitable for most applications. Also, the Loctite® Hysol® 175-AIR and 175-AIR-HT systems are solvent-free and non-toxic, so there are none of the environmental problems often associated with other adhesive applicators.

Designed to comply with worldwide safety standards, the Loctite® Hysol® 175-AIR and 175-AIR-HT also feature a totally enclosed heater housing, and are fitted with thermal fuse protection.

3. Technical Data

Dimensions (L x H x W):	approx. 11 13/16" x 9 15/32" x 2 17/32" (Approx. 300 x 240 x 65 mm)
Total weight:	approx. 3 lbs. (1.4 Kg)
Connection cable with mains plug:	10 ft (3 m) long
Operating voltage:	110-120 VAC 50/60Hz
Power consumption	500W
Heating up time:	10 minutes
Operating temperature:	175-AIR approx. 383°F (195°C) 175-AIR-HT approx. 400°F (204°C)
Diameter of adhesive inlet:	1 11/16" (43 mm)
Extension cable:	max. 65ft (20 m) long
Wire cross section:	at least 16 a.w.g. (1.5 mm ²)
Air Supply / Pneumatic	Minimum 45 p.s.i. (3 bar) Maximum 100 p.s.i. (7 bar)

4. Installation



Before using the tool for the first time check it carefully for signs of external damage. If any transit damage is found DO NOT USE THE TOOL - return it to your supplier immediately.

Steps 1 – 5 should be followed before connection to the mains supply:



1. Insert the applicator stand into the grooves at the base of the handle. Stand applicator on a flat surface.
2. Connect the air supply hose to a clean, dry and regulated air supply using the Quick-Disconnect fitting provided (use of a filter/regulator is recommended)
3. Pull piston back fully and rotate upwards.
4. Load two adhesive cartridges into the barrel of the tool and push fully forward.
5. Rotate the piston down and slide forward fully until it contacts the rear of the adhesive cartridge - it should engage about 5/16" (6-8mm) into the applicator barrel.

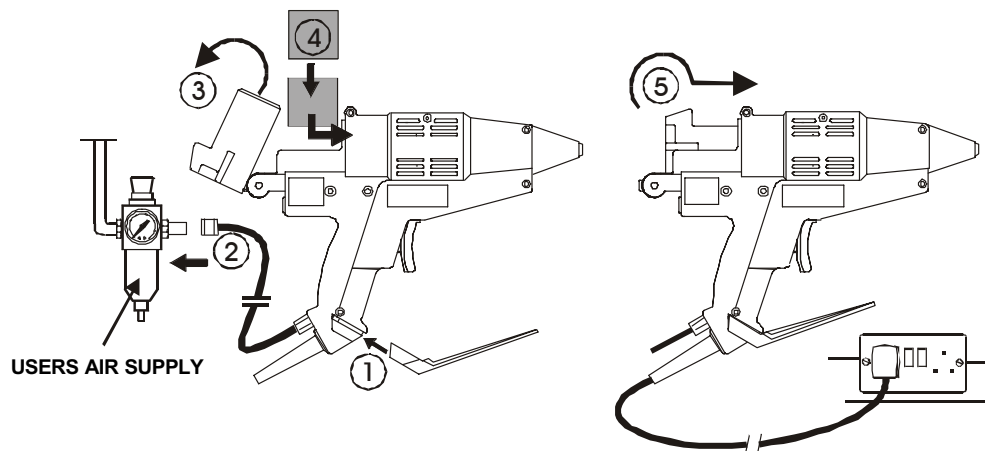

6. Connect tool to main power supply.
7. Red 'Power On' indicator light illuminates.
8. Allow the applicator to thoroughly warm up for 10 minutes. Do not attempt to operate the applicator until this time has elapsed.

5. Operation

Normal use:

- Fit the stand and place the applicator in an upright position on a flat surface.
- Plug the applicator into the power supply socket, and switch on the power. Wait 10 minutes for the applicator to reach its normal operating temperature.
- Squeeze the trigger to advance the piston and extrude molten adhesive through the nozzle.
- To stop extruding adhesive simply release the trigger.



During use, the piston will advance into the barrel as the trigger is pulled. A point will be reached where the piston no longer advances, and the sound of air escaping can be heard - this indicates that the applicator needs reloading.

- Release the trigger.
- Pull the piston back.
- Insert a new adhesive cartridge.
- Operate the tool normally.

5.1. Adhesive Flow Rate Adjustment

The flow rate of adhesive is dependent on the air pressure to the piston, and this is adjusted by varying the setting of the pressure regulator on the air supply to the applicator.

The air pressure operating range for the applicator is:

Minimum	45 p.s.i. (3 bar)
Maximum	100 p.s.i. (7 bar)

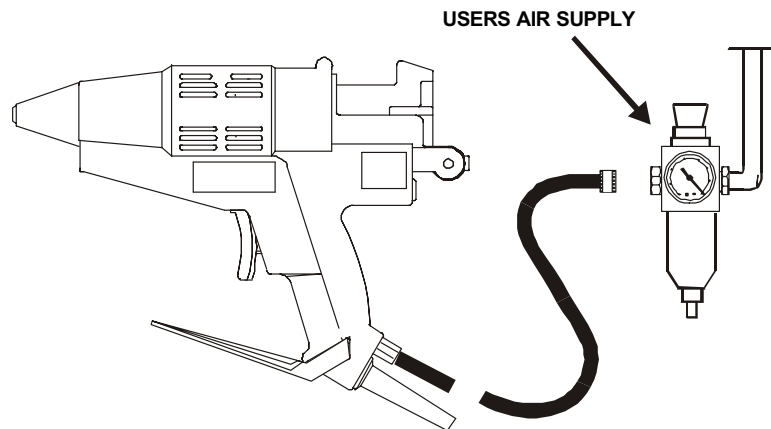

6. Application Hints

As with all adhesives, performance depends on conditions of use. Suggestions or recommendations contained herein are for guidance only, since actual conditions of use are outside the supplier's control.

- Ensure that the surfaces to be bonded are dry, free from dust, grease, and loose particles.
- Apply adhesive to one surface only. Bring the two surfaces together immediately, quickly making any further adjustments. Hold the joint for 20 – 30 seconds to complete the bond.
- When gluing dissimilar materials, apply the adhesive to the least heat conductive of the two.
- On materials that are cold to the touch, a better bond can be made by pre-warming them before applying adhesive.
- Surplus adhesive can be trimmed using a sharp knife once it has cooled. Should molten adhesive drip onto a smooth or polished surface, allow it to cool completely before removal.
- Spots or blobs of adhesive are recommended for work pieces having a large surface area, or which are particularly long.
- Applying the adhesive in wavy lines is recommended for gluing textiles or similar materials.
- Foam materials, like polystyrene, can be easily bonded to other surfaces. However the adhesive must be applied to the other surfaces, not to the foam.
- Use only genuine Loctite® Hysol® adhesives to ensure reliable performance. Loctite® Hysol® adhesives are non-toxic and non-flammable.

7. Troubleshooting



Before proceeding with any repair or maintenance operation disconnect the tool from the mains electricity supply.

Glue “Backup” and “Meltdown”

“Backup” occurs when hot molten adhesive in the glue chamber is forced back between the barrel wall and the outside surface of the adhesive cartridge and piston. Once this adhesive cools, it may lock the adhesive cartridge in the barrel, preventing, or at least restricting, normal extrusion. By far the most likely cause of backup is allowing insufficient warm-up time before operating the tool (the molten glue in the glue chamber cannot escape forwards because the nozzle is blocked, due to being insufficiently warm). In the vast majority of cases the backup self-clears once the tool, having fully reached operating temperature, is operated again.

“Meltdown” occurs when the rear of the adhesive cartridge softens to the extent that it is not rigid enough to drive the cartridge forward without collapsing. As with backup, the molten adhesive can solidify, potentially locking the cartridge and / or piston into the barrel. Meltdown is caused by leaving the tool switched on for extended periods of time without operating it. It is recommended that, if the tool is to be left standing for forty minutes or more, it should be switched off and only switched back on when preparing to use it again.



The Loctite® Hysol® 175-AIR and 175-AIR-HT tools are fitted with specially coated pistons which have non-stick characteristics far superior to any PTFE coating; this minimizes the effect of any backup or meltdown, should it occur.

FOR ANY REPAIRS OR ADJUSTMENTS – OTHER THAN THOSE DETAILED IN THIS MANUAL – PLEASE CONTACT 1-800-LOCTITE.

8. Care and Maintenance



Every attempt has been made to make this exceptionally powerful tool both reliable and trouble-free. However the following precautions should be noted:

- Make sure that the applicator is up to temperature before attempting to operate.
- Do not leave the applicator switched on for long periods without use. If the applicator is not to be used for forty minutes or more, switch it off and restart when required.
- Keep the applicator upright when not in use, never lay it on its side. Always use the stand provided, or the optional bench stand or suspension unit (see Spares and Accessory lists at the end of this manual).
- Do not use excessive force on the trigger. Ensure that the tool has fully warmed up before use.
- Keep the nozzle clean to prevent adhesive build-up. This is easily done by wiping the nozzle with clean paper or cloth while the nozzle is still warm.

9. Accessories and Spare Parts

Spare Parts	Part Number
2-Part Nozzle Assembly - supplied with tool	985078
Nozzle Adapter	985088
Applicator Stand	985069
Nozzle Shroud Kit, Qty 5	985223
Barrel PTFE	985071
Barrel Support Assembly	985091
Piston Support Assembly	985093
Piston Assembly	985095
Piston Support O-ring Kit, Qty 5	985234
Thermostat Assembly, 383°F (195°C)	985079
Thermostat Assembly, 400°F (204°C) (for polyamides)	985068
Heater Assembly 120 Volts	985080
PCB Assembly	985083
Thermal Fuse, Spacer Assembly	985076
Valve Body Airline Adapter	985240
Heater Housing Kit For 98036 (EVA Adhesive)	985227
Qty 1 – O-ring Heater Housing, item 5	
Qty 1 – Heater Housing, item 6	
Qty 1 – Ground Screw, item 35	
Qty 1 - Lock Washer, item 39	
Heater Housing Kit For 98040 (Polyamides Adhesives)	985237
Qty 1 – O-ring Heater Housing, item 44	
Qty 1 – Heater Housing, item 45	
Qty 1 – Ground Screw, item 35	
Qty 1 - Lock Washer, item 39	
Handle Kit	985228
Qty 2 – Moulded handles, item 1	
Qty 6 – Casing Screws, item 34	
Piston Support Hardware Kit	985229
Qty 1 – Washer, special with 4 holes, item 30	
Qty 1 – Pivot o-ring, item 26	

Qty 1 - Washer, flat nylon, item 40
Qty 6 – Casing screws, item 34

Trigger Valve Kit	985230
Qty 1 – Polytube, item 19	
Qty 1 - Trigger Valve Assembly, item 14	
Qty 1 – Philips Pan Head Screw, item 33	

U.S. Cord Set Assembly	985231
Qty 1 – Cordset, item 17	
Qty 1 – Clamp, item 18	
Qty 2 – Screws, item 38	

Accessories	Part Number
Nozzle 1-Hole Kit, Qty 5, 0.080" (2 mm) orifice	985225
Nozzle 2-Hole	985110
Nozzle 3-Hole	985111
Extension Nozzle 0.120" (3 mm)	985112
Needle Extension Nozzle 0.050" (1.3 mm)	985113
Spreader Extension Nozzle 0.250" (6 mm)	985114
'L' Nozzle, overlap carton sealing	985115
'T' Nozzle, center flap carton sealing	985116
(Note: the nozzle shroud cannot be re-fitted with some optional nozzle)	
Tool Hanger/Balancer	985243
Heavy-Duty Free-Standing Metal Stand	985087

10. Warranty

This applicator is guaranteed against faulty workmanship, materials and malfunction for a period of **12 months** from the date of purchase. This guarantee does not apply:

1. If the applicator has been dropped, damaged due to careless handling or has not been used in accordance with the manufacturer's instructions.
2. If the applicator has been modified in any way.
3. If the applicator has been opened or the electrical cable has been damaged or replaced.
4. If adhesive other than formulations supplied by the manufacturer of the applicator have been used.

The manufacturer undertakes to repair or replace at their discretion. The tool will be returned to the distributor or user freight paid.

Seller and Manufacturer's only obligation shall be to replace such quantity of the product proved to be defective. Neither seller nor manufacturer shall be liable for any injury, loss or damage direct or consequential, arising out of the use, or the inability to use, the product. User shall determine the suitability of the product for his intended use and the user assumes all risks and liability whatsoever in connection therewith.

11. Appendix.

Pictures of available nozzles/accessories.

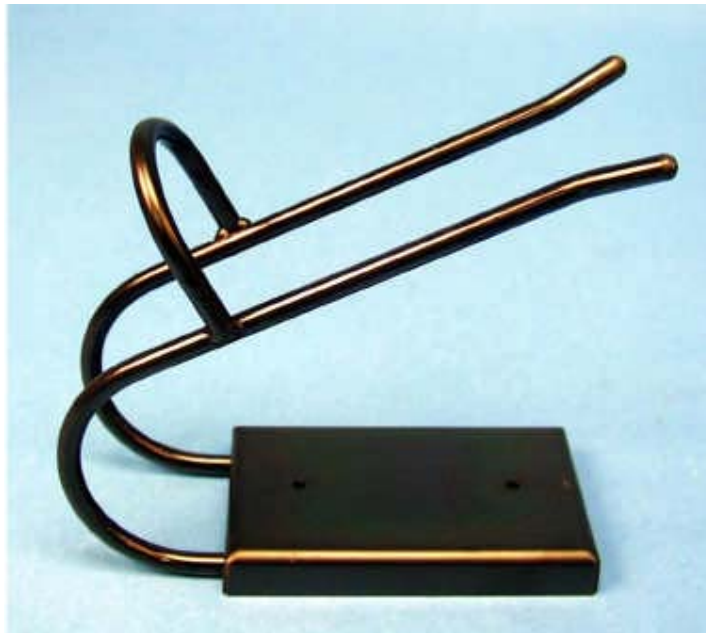

985087
HEAVY DUTY FREE-STANDING
METAL STAND



985243
TOOL HANGER / BALANCER

12. Exploded View.

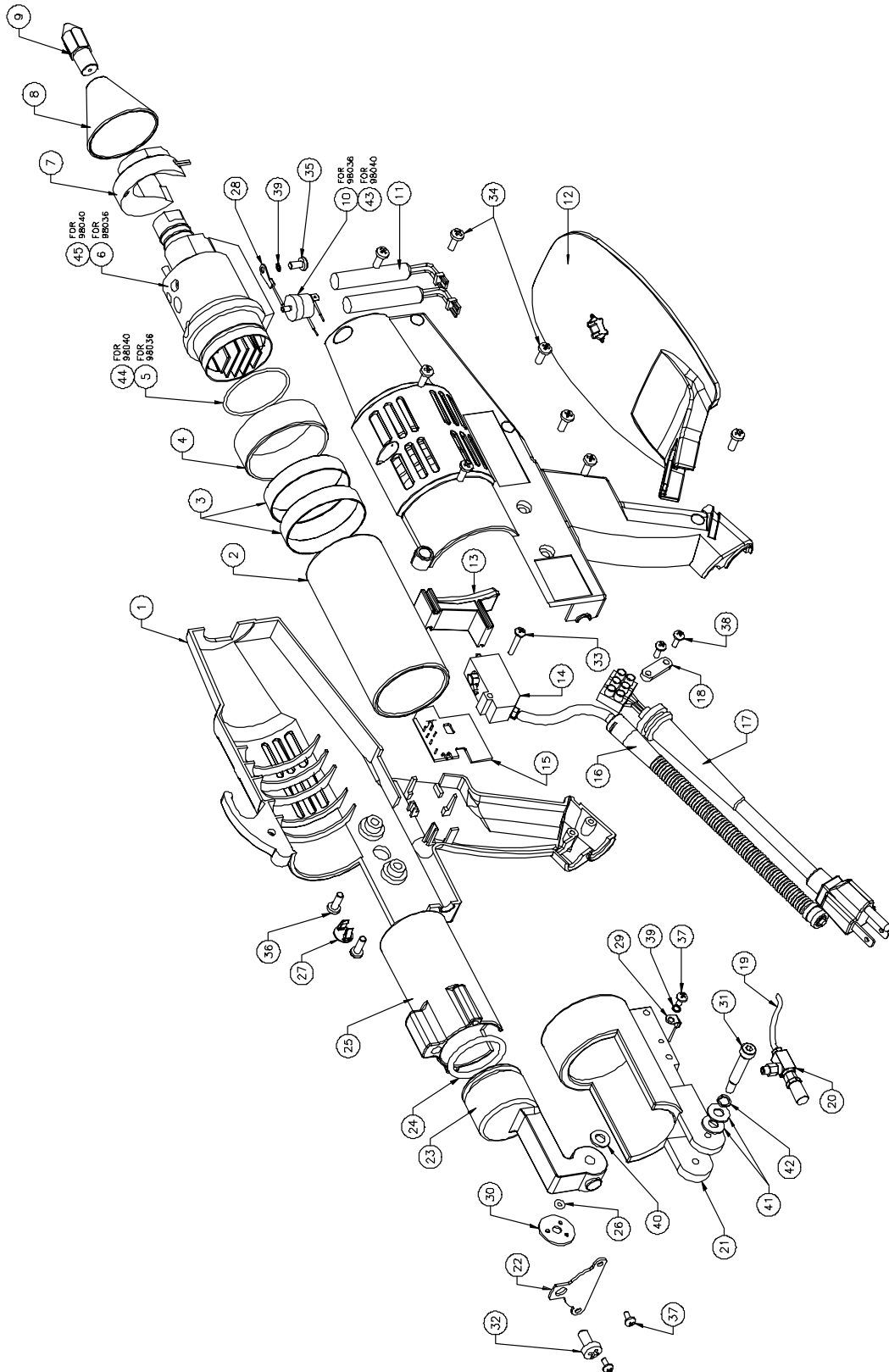

13. Parts List.

45	1	HEATER HOUSING ASSEMBLY	HEATER HOUSING KIT	985237
44	1	HEATER HOUSING O-RING	HEATER HOUSING KIT	985237
43	1	THERMOSTAT ASSEMBLY, 215°C, 419°F		985068
42	1	HELICAL SPRING LOCK WASHER, 1/4", BLACK OXIDE		
41	2	WASHER, 1/4", FLAT, BRIGHT ZINC PLATE		
40	1	WASHER, FLAT, NYLON	PISTON SUPPORT HARDWARE KIT	985229
39	2	HELICAL SPRING LOCK WASHER	HEATER HOUSING KIT	985227
38	2	PHILLIPS PAN HEAD SCREW, SELF TAPPING, #6-20 X 3/8, BRIGHT ZINC	US CORDSET KIT	985231
37	3	PHILLIPS ROUND HEAD SCREW, #6-32 x 1/4 LONG		
36	4	PHILLIPS ROUND HEAD SCREW, #10-32 x 5/8 LONG, BLACK OXIDE		
35	1	EARTH (GROUND) SCREW, 4BA x 1/2" LONG	HEATER HOUSING KIT	985227
34	6	CASING SCREW, 12mm LONG SELF-TAPPER	AVAILABLE IN MULTIPLE KITS	985228 OR 985229
33	1	PHILLIPS PAN HEAD SCREW, SELF TAPPING, #6-20 X 3/4, BRIGHT ZINC	TRIGGER VALVE KIT	985230
32	1	PHILLIPS PAN HEAD SCREW, 1/4-20 x 1/2 LONG, BLACK OXIDE		
31	1	SOCKET HEAD SHOULDER SCREW, 1/4" x 1"		
30	1	WASHER, SPECIAL WITH 4 HOLES	PISTON SUPPORT HARDWARE KIT	985229
29	1	BARREL SUPPORT EARTH WIRE ASSEMBLY		
28	1	HEATER HOUSING EARTH WIRE ASSEMBLY		
27	1	RED LENS		
26	1	PIVOT O-RING	PISTON SUPPORT HARDWARE KIT	985229
25	1	PISTON		985095
24	1	PISTON SUPPORT O-RING	PISTON SUPPORT O-RING KIT	985234
23	1	PISTON SUPPORT ASSEMBLY		985093
22	1	PISTON PLATE		
21	1	BARREL SUPPORT		985091
20	1	EXHAUST SILENCER ASSEMBLY		
19	1	POLYTUBE	TRIGGER VALVE KIT	985230
18	1	CORDSET CLAMP	US CORDSET KIT	985231
17	1	U.S. CORDSET ASSEMBLY, 3M	US CORDSET KIT	985231
16	1	AIRLINE ASSEMBLY, 3M		
15	1	CONNECTOR & LIGHT PCB ASSEMBLY, 120 VOLT		985083
14	1	TRIGGER VALVE ASSEMBLY	TRIGGER VALVE KIT	985230
13	1	TRIGGER		
12	1	DISPENSER STAND		985069
11	2	HEATER ASSEMBLY, 120 VOLT, 250 WATT		985080
10	1	THERMOSTAT ASSEMBLY, 195°C, 383°F		985079
9	1	NOZZLE BODY ASSEMBLY		985078
8	1	NOZZLE SHROUD	NOZZLE SHROUD KIT	985223
7	1	THERMAL FUSE & SPACER ASSEMBLY		985076
6	1	HEATER HOUSING ASSEMBLY	HEATER HOUSING KIT	985227
5	1	HEATER HOUSING O-RING	HEATER HOUSING KIT	985227
4	1	LOCK RING, ALUMINIUM		
3	2	BARREL SUPPORT RING		
2	1	BARREL, PTFE		985071
1	1	HANDLES, PAIR	HANDLE KIT	985228
ITEM	QTY.	DESCRIPTION	REBUILD KITS	AVAILABLE PART NO.

PARTS LIST